

GENERAL DESCRIPTION

This miniature connector series is designed to be compatible with the small semi-rigid cables that have very low VSWR up to 22 GHz. In addition, other connectors in the series can accommodate flexible coaxial cable, PCB, flange, surface and bulkhead configurations. These connectors are ideal for use in rack and panel applications.

MATERIALS

Bodies & Other Parts: Stainless Steel per ASTM A582 or equivalent.
 Female Contacts: Beryllium Copper per ASTM B196 or equivalent.
 Male Contacts: Brass per ASTM B16 or equivalent.
 Insulators (Dielectric): PTFE Fluorocarbon per ASTM D1710 or equivalent.
 Gaskets: Silicone rubber per ZZ-R-765, Class II, Grade 50.

ELECTRICAL

Impedance: 50 Ohms Nominal
 Frequency Range: DC-22 GHz
 Insulation Resistance: 5,000 Megohms min.
 Voltage Rating: 335 VRMS
 Dielectric Withstanding: 1,500 VRMS at sea level
 Voltage Standing Wave Ratio (VSWR): 1.05 + .005 (f) GHz max.
 Contact Resistance:
 Outer Contact: 2.0 Milliohms
 Center Contact: 2.0 Milliohms

ENVIRONMENTAL

Temperature rating: -65°C to +125°C
 Vibration: MIL-STD-202, Method 204
 Shock: MIL-STD-202, Method 213
 Thermal Shock: MIL-STD-202, Method 107
 Corrosion (Salt Spray): MIL-STD-202, Method 101
 Moisture Resistance: MIL-STD-202, Method 106

PLATING OPTIONS

Gold: Per MIL-G-45204, Type II, Grade C
 Nickel: Per QQ-N-290, Class II
 Silver: Per QQ-S-365, Type II, Grade A

MECHANICAL

Force to Engage: 3 lbs. max.
 Force to Disengage: 1.5 max.
 Center Contact Retention: 6 lbs. min.
 Allowable Misalignment:
 Rigid Mounting: Axial: .015 max., Radial: .008 Max.
 Floating Assembly: Axial: .060 max., Radial: .020 Max.
 Mating Cycles: 1,000 min.

DESIGN IN ACCORDANCE WITH

US MIL-PRF-31031
 US MIL-STD-348
 ITELLICONNECT: ES101, ES103

JACK INTERFACE (FEMALE CONTACT)

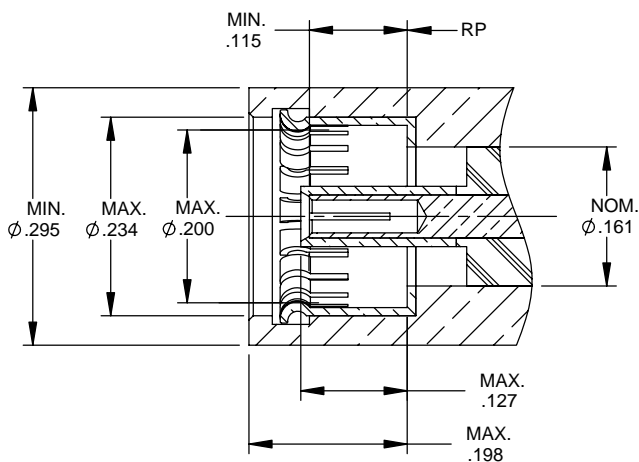
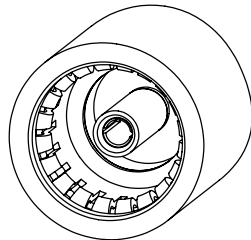

PLUG INTERFACE (MALE CONTACT)

