

MATERIAL/FINISH PROPERTIES

MATERIAL PROPERTIES:
 BODY: BRASS PER ASTM B16 OR EQUIVALENT
 CONTACT: BRASS PER ASTM B16 OR EQUIVALENT
 INSULATORS: PTFE PER ASTM D1710 OR EQUIVALENT
 GASKETS: SILICONE RUBBER PER ZZ-R-765 OR EQUIVALENT

PLATING PROPERTIES:
 OTHER METAL PARTS: .000100 MIN. NICKEL PER QQ-N-290
 CONTACTS: .000010 MIN. GOLD PER MIL-G-45204 OVER
 .000050 MIN. NICKEL PER QQ-N-290

MECHANICAL/ELECTRICAL PROPERTIES

CONNECTOR MEETS: MIL-STD-348 FIG. 202-1, MIL-PRF-49142
 CONNECTOR MEETS: RoHS 2002/95/EC STANDARDS
 CONNECTOR DURABILITY: 500 CYCLES MIN.
 CABLE: TRIAX, CABLE GROUP 17, PER ES102
 ASSEMBLY INSTRUCTIONS: A1183
 IMPEDANCE: NON CONSTANT
 VOLTAGE RATING: 400 VRMS
 INSULATION RESISTANCE: 5,000 MEGOHMS
 CONTACT RESISTANCE:
 CENTER: 5.0 MILLOHMS MAX.
 INTERMEDIATE: 0.5 MILLOHMS MAX.
 OUTER: 0.5 MILLOHMS MAX.

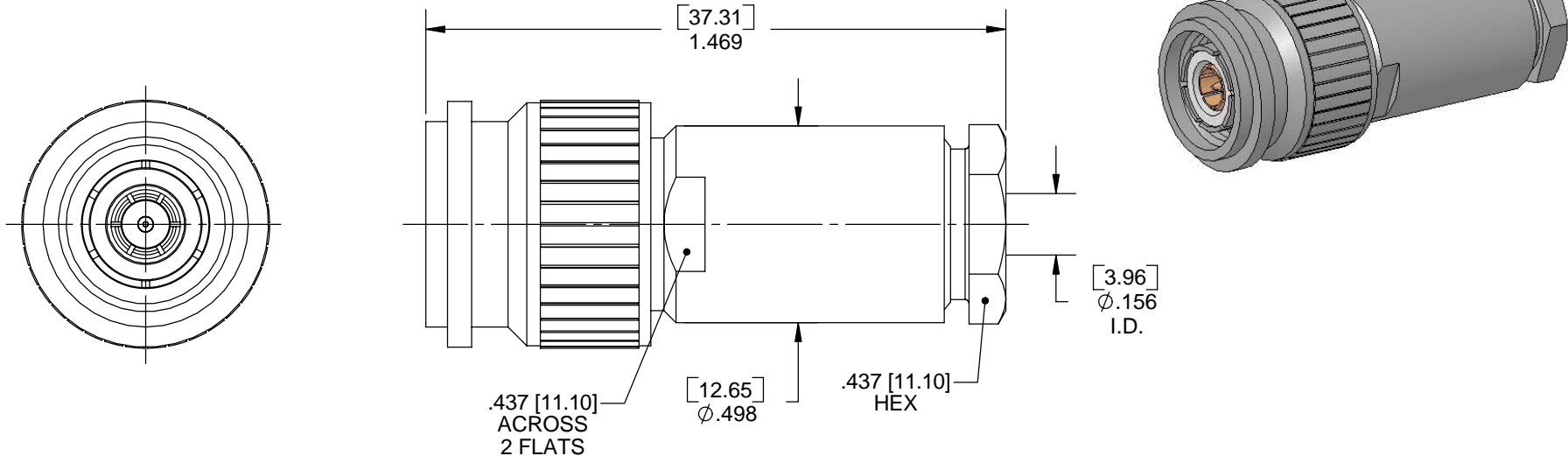

NOTES: 1. ALL ITEMS SHIP LOOSE IN BAG

A	NPR 404	TLB	05/05/06
REV	DESCRIPTION	APPR	DATE

IntelliConnect

UNLESS OTHERWISE SPECIFIED
 ALL DIMENSIONS ARE REFERENCE
 X.XXX DIM'S = INCHES * [X.XX] DIM'S = MILLIMETERS
 SURFACE FINISH: 63 MICRO MAX.
 ALL DIAMETERS TO BE CONCENTRIC WITHIN .005 F.I.M.

TITLE: TRT STRAIGHT CABLE U/G CLAMP PLUG

MATERIAL & FINISH: PER TABLE ABOVE

DRAWN BY: SRS	CHECK BY: PCS	APPR. BY: TLB
DATE: 05/05/06	DATE: 05/05/06	DATE: 05/05/06
CAGE CODE NO: 5N5S5	SCALE: 2.5:1	SIZE: A
SALES DRAWING	PART NO. 0133-P1NN-417-100N	SHEET 1 OF 1